

61313

Hitch application

Chev/Gmc Front Mount Camper Tiedown

For specific fit, see current fit list
in our fitlist at www.dsphitches.com

#61313

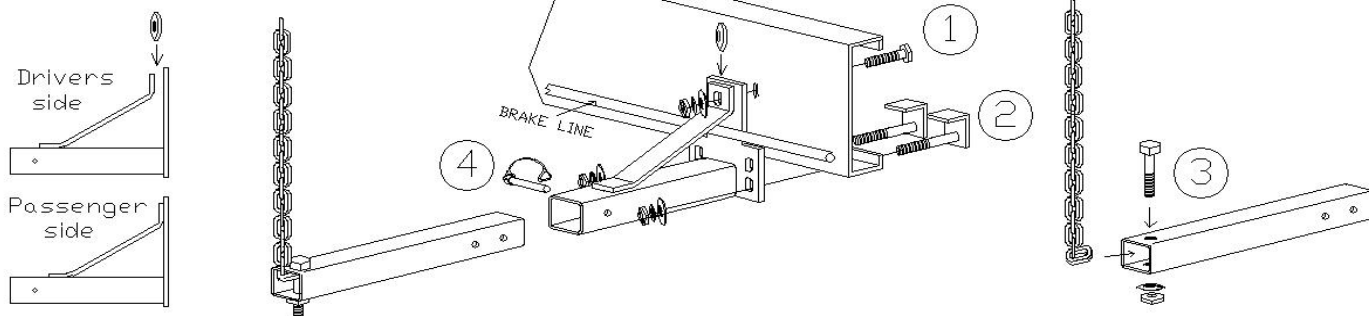

Parts List		Contents of Bolt Pack # 61313/B		Tools Required
1	Main Body Part #61315/MBD	2	Hex Bolt 1/2 x 1-3/4, Grade 5, UNC, Plated	1/2" Socket or Wrench 100 FT/LB Torque Wrench
1	Main Body Part #61315/MBP	6	Lock Washer 1/2, Grade 5, UNC, Plated	
2	Tube Chains #63102	6	Flat Washer 1/2, Plated	Drill Application
4	Square U-Bolts #X63480	6	Hex Nut 1/2, Grade 5, UNC, Plated	
1	Bolt Pack 61313/B	2	Quick Pin Round 3/8 x 2-1/4	
1	Instructions T6000 Series	2	Hex Bolt 3/8 x 2-1/4, Grade 5, UNC, Plated	
		2	Lock washer 3/8, Grade 5, Plated	
		2	Hex Nut 3/8, Grade 5, UNC, Plated	
		1	# 91510 3/8 Reinforcement Spacer (round)	
		2	Chain 30", 23 links	
Shipping Weight	31.2 lbs 14.2 kg			

- 1) Start with the driver's side installation. The driver's side main body has a gap to slide the brake cable through (not applicable to all truck models). Locate the area between the cab and the box mounts. Some truck models have two holes in this location, others do not. One or two holes per side may need to be drilled. Secure main body in place in hole (1) with 1/2 x 1-3/4 hex bolt, #91510 3/8 spacer, flat washer, lock washer and nut.
- 2) Place the square u-bolts on c-channel frame (2) and through holes in the main body and secure in place with flat washer, lock washer and nut.
- 3) Hand tighten all fasteners.
- 4) Repeat for passenger side.
- 5) Tighten all mounting fasteners to the correct torque specifications listed below.
- 6) For the tube chains: insert the first link into the tube as shown in picture (3) and insert 3/8 hex bolt through tube and chain and secure in place with 3/8 lock washer and 3/8 nut. Tighten all fasteners.
- 7) Fasten tube chain to main body using the supplied quick pin. Remove when not in use.

Bolt Size	Grade 5 Torque	Metric	Grade 8.8 Torque
3/8	30 Ft. Lb	8 mm	18 Ft. Lb.
7/16	54 Ft. Lb	10 mm	36 Ft. Lb.
1/2	72 Ft. Lb.	12 mm	75 Ft. Lb.
5/8	150 Ft. Lb	14 mm	103 Ft. Lb.
3/4	245 Ft. Lb	Maximum torque for weld or weld nuts is 38 FT/Lb	

Warning: Check Fasteners annually or before usage, if the Tiedown is damaged replacement may be necessary.
DO NOT drill or alter this product. This product is only intended for the application listed above, see vehicle owner's manual for maximum camper capacity (GVWR). This product is intended for usage with the correct towing accessories and not to be used with tow ropes, cables, chains or any type of stretch or elastic rope.

DSP Hitches are manufactured by 2114391 Alberta Ltd., Edmonton, Alberta, Canada
For more information on DSP and DSP products call 1-800-265-3377 or visit us at www.dsphitches.com