

61311
Front Camper Tiedown Hitch Application
Chev/GMC Front Mount Camper Tiedown
For specific fit, see current fit list in our fitlist at www.dsphitches.com

#61311

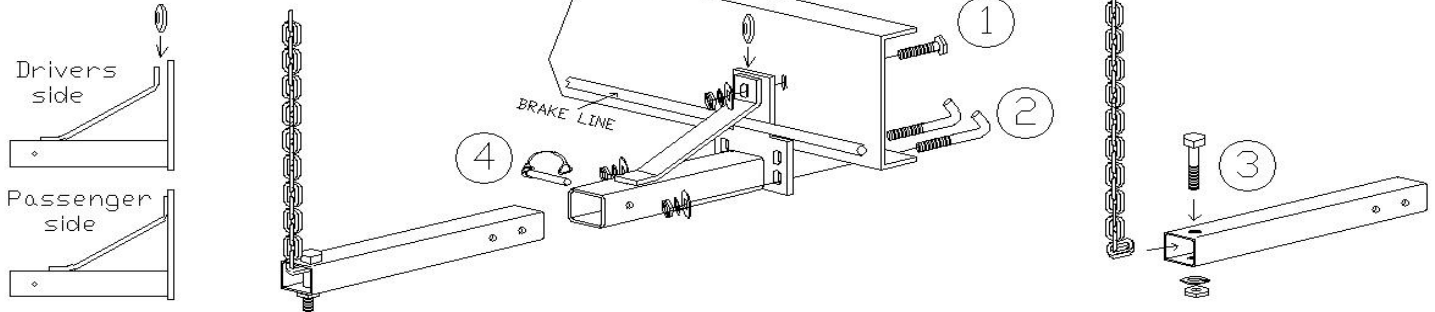

Parts List		Contents of Bolt Pack # 61311/B		Tools Required
1	Main Body Part #613153/MBD	2	Hex Bolt 1/2 x 2, Grade 5, UNC, Plated	1/2" Socket or Wrench 100 FT/LB Torque Wrench
1	Main Body Part #61315/MBP	6	Hex Nut 1/2, Grade 5, UNC, Plated	
2	Tube Chains #63102	6	Flat Washer 1/2, Plated	
1	Bolt Pack 61311/B	6	Lock Washer 1/2, Grade 5, UNC, Plated	
1	Instructions T6000 Series	1	# 91510 3/8 Reinforcement Spacer (round)	
		2	Quick Pin Round 3/8 x 2-1/4	
		2	CT Specialty J Bolt # 63107	
		2	Hex Bolt 3/8 x 2-1/4, Grade 5, UNC, Plated	
		2	Lock washer 3/8, Grade 5, Plated	
		2	Hex Nut 3/8, Grade 5, UNC, Plated	
Shipping	25 lbs	2	Chain 30", 23 links	No Drill Application
Weight	11.4 kg			

- 1) Start with the driver's side installation. The driver's side main body has a gap to slide the brake cable through (not applicable to all truck models). Locate the area between the cab and the box mounts. Position the main body in the area of this location. Secure loosely in place with 1/2 x 2 hex bolt, #91510 3/8 spacer, flat washer, lock washer and nut.
- 2) Install the specialty j-bolts on the lower edge of the frame rail (2) clamping the tiedown into position with flatwasher, lock washer and nut.
- 3) Repeat on passenger side.
- 3) Tighten all mounting fasteners to the correct torque specifications listed below.
- 4) For the tube chains: insert the first link into the tube as shown in picture (3) and insert 3/8 hex bolt through tube and chain and secure in place with 3/8 lock washer and 3/8 nut. Tighten all fasteners.
- 5) Fasten tube chain to main body using the supplied quick pin. Remove when not in use.

Bolt Size	Grade 5 Torque	Metric	Grade 8.8 Torque
3/8	30 Ft. Lb	8 mm	18 Ft. Lb.
7/16	54 Ft. Lb	10 mm	36 Ft. Lb.
1/2	72 Ft. Lb.	12 mm	75 Ft. Lb.
5/8	150 Ft. Lb	14 mm	103 Ft. Lb.
3/4	245 Ft. Lb	Maximum torque for weld or weld nuts is 38 FT/Lb	

Warning: Check Fasteners annually or before usage, if the Tiedown is damaged replacement may be necessary.
DO NOT drill or alter this product. This product is only intended for the application listed above, see vehicle owner's manual for maximum camper capacity (GVWR). This product is intended for usage with the correct towing accessories and not to be used with tow ropes, cables, chains or any type of stretch or elastic rope.

DSP Hitches are manufactured by 2114391 Alberta Ltd., Edmonton, Alberta, Canada
For more information on DSP and DSP products call 1-800-265-3377 or visit us at www.dsphitches.com