

Hitch application	Product Description	Rating			Parts Reference			
		G.T.W.	Vertical Load	Crossbar	H-Bracket	Bolt Pack	Sides	
71831	24" Ford UBM Standard	17,000 lbs/7,728 kg	4,250 lbs/1,932 kg	73101	73202	73853	73870 (Box incl. Sides and Anchors)	
71832	24" Ford UBM Double Tilt	17,000 lbs/7,728 kg	4,250 lbs/1,932 kg	73151	73215	73859	73870 (Box incl. Sides and Anchors)	
71834	35" Dodge UBM Double Tilt	17,000 lbs/7,728 kg	4,250 lbs/1,932 kg	73151	73215	73859	73871 (Box incl. Sides and Anchors)	
71842	24" Ford UBM Falcon Double Tilt	20,000 lbs/9,072 kg	5,000 lbs/2,268 kg	73181	73963	73859	73870 (Box incl. Sides and Anchors)	
71844	35" Dodge UBM Falcon Double Tilt	20,000 lbs/9,072 kg	5,000 lbs/2,268 kg	73181	73964	73859	73871 (Box incl. Sides and Anchors)	
73870	24" UBM Conversion Kit for Standard/Double Tilt	-	-	-	-	-	73870 (Box incl. Sides and Anchors)	
73870A	24" UBM Replacement Anchors (Set of 2)	-	-	-	-	-	-	
73871	35" UBM Conversion Kit for Standard/Double Tilt	-	-	-	-	-	73871 (Box incl. Sides and Anchors)	
73871/DF	35" Dodge UBM Replacement Anchors Front	-	-	-	-	-	-	
73871/DR	35" Dodge UBM Replacement Anchors Rear	-	-	-	-	-	-	

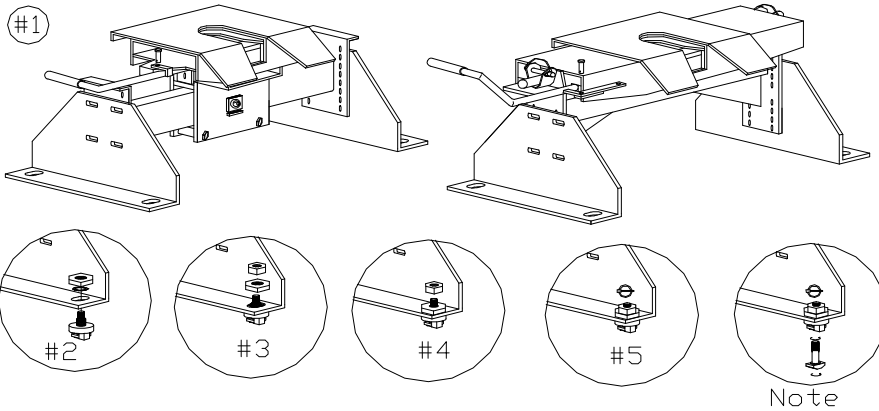

UBM Anchor Hardware

- 5/16 x 1 3/4 Lynch Pin
- 5/8 Hex Nut
- 1" Jam Nut
- 1" Ext.Tooth Lockwasher
- UBM Bolt Housing
- UBM Slotted T-Bolt

Note

NOTE: FALCON Hitch not pictured.

Item#	Description	Ship. Weight	Ship. Dimens. in inch	Contents of Bolt Pack DPO/DPEL #73853	Contents of UBM Anchor Set #73870A
73101	24" Crossbar 17,000 DPO/DPEL	58.6 lbs	37 x 15 x 5	8 Hex Bolt 1/2 X 1-1/4, Grade 5 UNC Plated	2 UBM Slotted T-Bolt
73151	12" Crossbar 17,000 DPDT	45 lbs	29 x 15 x 6	8 1/2, Grade 5, UNC, Plated	2 UBM Bolt Housing
73181	14" Falcon Crossbar 20	53.2 lbs	22 x 14 x 5	8 Hex Nut 1/2, Grade 5, UNC, Plated	2 1" External Tooth Lockwasher
73202	24" H-Bracket DPO	21.8 lbs	31.5 x 16 x 6.5	4 Hair Pin Clip #9 (Class III) 5/32"x3-5/16"	2 1" Jam Nut
73215	24" H-Bracket DPDT	41.2 lbs	31.5 x 16 x 6.5	2 Quick Pin Square 3/8 x 2-1/4	2 5/8" Hex Nut
73961	Falcon 24" H-Bracket Standard	32.8 lbs	34 x 15.5 x 9	Contents of Bolt Pack DPDT #73859	2 5/16 x 1-3/4 Lynch Pin
73963	Falcon 24" H-Bracket DT	53.8 lbs	44.5 x 16.5 x 7	8 1/2 X 1-1/4 Hex Bolts, Grade 5 UNC Plated	Tools Required
73870	UBM Sides w/Anchors	41 lbs	17.5 x 13.5 x 5.5	8 1/2 Lock Washer 8 1/2 Hex Nut 4 Small Hair Pins	3/4" Wrench and Socket 100 FT Torque Wrench

1. Assembly of the Upper Half

- 1a. Assembly of Fifth Wheel Hitch: Assemble the upper half of the fifth wheel hitch (sides, h-brackets and crossbar) to the required height, assuring clearance between the trailer and the towing vehicle.
- 1b. Assembly of UBM Gooseneck Hitch: Remove 1-3/8" lock washer and 1-3/8" hex nut from hitchball and install on gooseneck crossbar. Torque to clamp load: 32.550 746 FT.LB.

2. Assembly of the anchor system: Place the UBM Slotted T-Bolt into the UBM Bolt Housing and insert into the 1" hole located on the hitch sides.

3. Loosely thread the 1" external tooth lockwasher and 1" jam nut onto the UBM Bolt Housing from the top (see diagram 2). Thread the 5/8" hex nut onto the UBM Slotted T-Bolt, covering the 5/16" hole. Drop the hitch into the mounting base located in the floor of the truck bed. Turn the UBM Slotted T-Bolt until it locks into the UBM Bolt Housing.
4. Centre the hitch in the truck box and tighten the 1" nuts to the sides.
5. Tighten the 5/8" hex nut, a wrench may be required, until the lynch pin can be inserted into the hole of the UBM Slotted T-Bolt. Instead of using a lynch pin a pad lock can be used to secure your hitch base from theft.

NOTE: If lynch pin cannot be fitted into the hole of the UBM Slotted T-Bolt, loosen the assembly and disengage the bolt from the UBM Bolt Housing. Turn UBM Slotted T-Bolt 180 degrees and re-tighten.

Maintenance: Check and tighten all fasteners on a regular basis.

Bolt Size	Grade 5 Torque	Metric	Grade 8.8 Torque
9/16	110 Ft. Lb	8 mm	18 Ft. Lb.
7/16	54 Ft. Lb	10 mm	36 Ft. Lb.
1/2	72 Ft. Lb.	12 mm	75 Ft. Lb.
5/8	150 Ft. Lb	14 mm	103 Ft. Lb.
3/4	245 Ft. Lb		

Maximum torque for weld or weld nuts is 38 FT/Lb

Warning: Check Fasteners annually or before usage, if the hitch is damaged replacement may be necessary

Do Not exceed hitch manufactures hitch ratings listed above, DO NOT drill or alter this product. This product is only intended for the application listed above, see vehicle owner's manual for maximum towing capacity (GVWR). This product is intended for usage with the correct towing accessories and not to be used with tow ropes, cables, chains or any type of stretch or elastic rope.

DSP Hitches are manufactured by 2114391 Alberta Ltd., Edmonton Alberta, Canada. For more information on DSP and DSP products call 1-800-265-3377 or visit us at www.dsphitches.com